

13.0.176

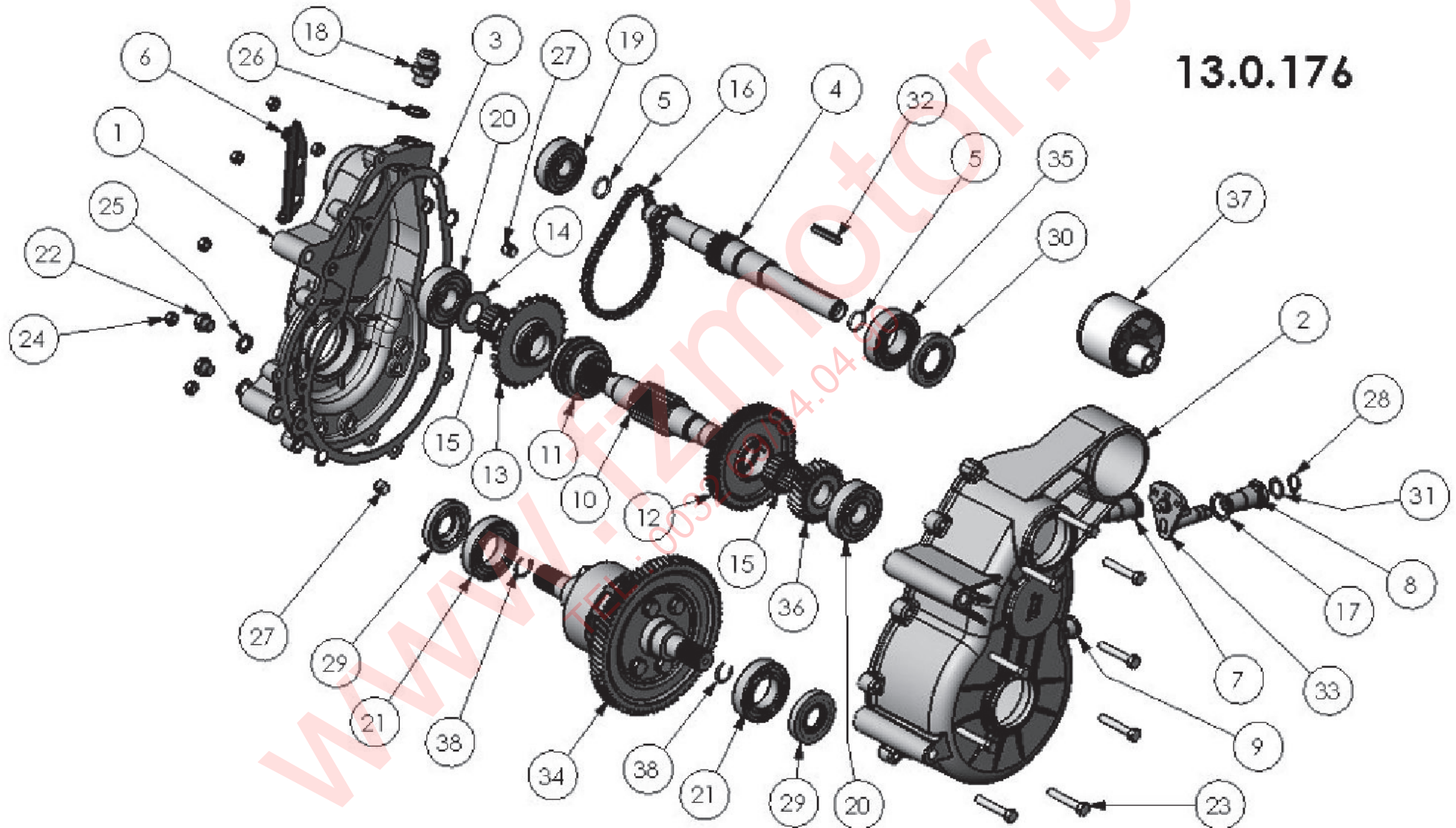



BOITE INVERSEUR RAPPORT 1/8

13.0.176

Rep.	Qte.	Code	modch.	DESIGNATION	DESIGNATION(it)	DESIGNATION(en)	DESIGNATION(al)	DESIGNATION(es)
1	1	13.1.823		Carter boîte de vitesse D	Carter	Crakcase	Kurbelwellenhäuse	Carte
2	1	13.1.824		Carter boîte de vitesse G	Carter	Crakcase	Kurbelwellenhäuse	Carte
3	1	13.1.821		Joint de boîte de vitesse	Guarnizione	Packing	Dichtung	Junta
4	1	13.2.291		Arbre d'entrée	Albero entrata	Input shaft	Eingangswelle	Eje de entrada
5	2	13.2.192		Joint OR	Guarnizione OR	OR Packing	Dichtung auslaß OR	Junta OR
6	1	13.1.827		Plaque arrêt de gaine sur boîte	Supporto	Support	Träger	Soporte
7	1	13.2.293		Vis sans bille	Vite	Screw	Schraube	Tornillo
8	1	13.2.185		Guide levier	Cierre	Lever guide	Hebelführung	Guia plancia
9	1	13.2.257		Bouchon	Tappo	Plug	Pfropfen	Tapon
10	1	13.2.196		Arbre intermédiaire	Albero intermedio	Intermediate shaft	Zwischenwelle	Eje intermedio
11	1	13.2.197		Manchon coulissant	Soffietto	Bellows	Balg	Fuelle
12	1	13.2.195		Pignon marche AV	Ingranaggio Marcia avanti	Forward gear	Zahnrad Vorwärtsgang	Eng.Marcha adelante
13	1	13.2.199		Pignon marche AR	Ingranaggio Retromarcia	Reverse gear	Zahnrad Rückwärtsgang	Eng. De marcha atras
14	1	13.2.200		Bague	Anello	Ring	Ring	Anillo
15	2	13.2.194		Roulement	Cuscinetto	Bearing	Lager	Cojinete
16	1	13.2.198		Chaine	Catena	Chain	Kette	Cadena
17	2	13.2.186		Rondelle sur boîte	Rondella	Washer	U.scheibe	Arandela
18	1	13.1.822		Event BV	Valvola di sfianto	Air valve	Entlüftungsventil	Valvula de escape
19	1	13.1.618		Roulement	Cuscinetto	Bearing	Lager	Cojinete
20	2	13.1.754		Roulement	Cuscinetto	Bearing	Lager	Cojinete
21	2	13.1.634		Roulement	Cuscinetto	Bearing	Lager	Cojinete
22	2	13.2.211		Bouchon	Tappo	Plug	Pfropfen	Tapon
23	9	00.2.058		Vis HM6-40/40 Z-B	Vite	Screw	Schraube	Tornillo
24	9	00.3.061		Ecrou nylstop HM6	Dado	Nut	Mutterschraube	Tuerca
25	2	13.2.210		Rondelle	Rondella	Washer	U.scheibe	Arandela
26	1	13.2.214		Rondelle	Rondella	Washer	U.scheibe	Arandela
27	2	13.2.189		Goupille élastique	Coppiglia elastica	Split pin	Splint	Grupilla



BOITE INVERSEUR RAPPORT 1/8

13.0.176

Rep.	Qte.	Code	modch.	DESIGNATION	DESIGNATION(it)	DESIGNATION(en)	DESIGNATION(al)	DESIGNATION(es)
28	1	13.2.182		Circlips	Circlips	Circlips	Circlips	Circlips
29	2	13.2.202		Bague d'étanchéité	Anello OR	Ring	O-ring	Anillo OR
30	1	13.2.190		Bague d'étanchéité	Anello OR	Ring	O-ring	Anillo OR
31	1	13.2.183		Anneau	Anello	Ring	Ose	Aro
32	1	13.1.459		Clavette	Chiavetta	Key	Paßfeder	Pasador
33	1	13.2.187		Arbre selecteur	Albero selettore	Selector shaft	Wählerswelle	Arbol selector
34	1	13.2.298		Kit différentiel 1/11	Differenziale completo	Differential assembly	Komplette Ausgleichsgetriebe	Diferencial completo
35	1	13.1.619		Roulement	Cuscinetto	Bearing	Lager	Cojinete
36	1	13.2.219		Engrenage 2ème réduction	Ingranaggio seconda riduzione	Second reduction gear	Zweite Umsetzung Getriebe	Engranaje 2nda reduccion
37	1	13.1.832		Silentbloc BV 442	Silentbloc	Sil.blok	Puffer	Silent-bloc
38	2	14.1.041		Anneau / Transmission	Anello / cambio	Ring / Transmission	Öse / Getriebe	Aro / Transmision

www.fzmotor.com  
 TEL.: 0032 69/84.04.90